

Dr.Gemini 2007

Installing Example

This is an example how to install and configure Dr.Gemini 2007 , slave units and actuator motors.

Cable type: The low voltage cables should be shielded and rodent resistant. The shield connects to GND. We recommend a light flexible cable like YSY-JZ. Sufficient thickness = .6 square mm

This example uses:

1. A SM58 actuator motor pulling the air inlets.
2. A SM59 actuator for the exhaust damper
3. Control signal for the fans, 0-10 V , is taken from the connecting PCB, where heating (on/off), sprinkling and humidifying also connects.

If your configuration have more units of the same type or other kind of actuator motors, please consult the User Guide.

Setting the dip switches on the local units

All units are connected to the "RS485 LOCAL" output, "A" to "A" and "B" to "B". To make the local units function correctly, it is important that they "listen" to the right "channel" on the communication line. This is done by setting the dip switches.

Left Room

Right Room

SM58 actuator motor pulling the air inlets, I %

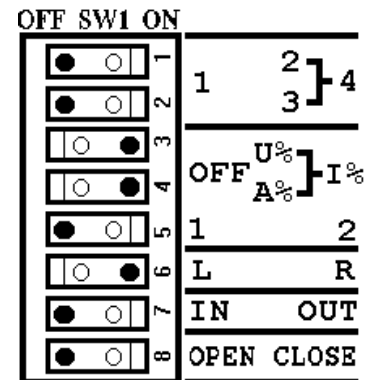
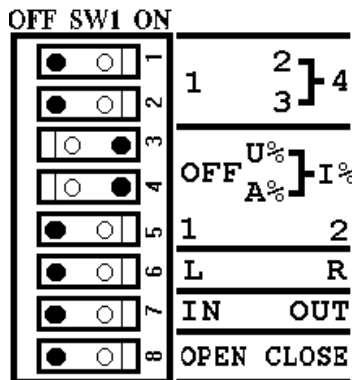

SM59 actuator motor pulling the exhaust dampers, U %

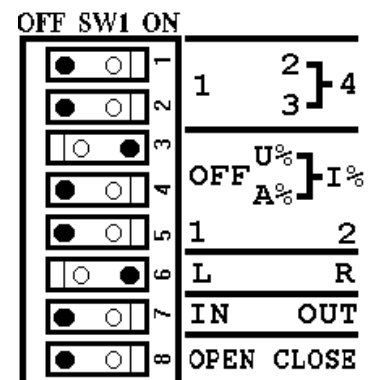
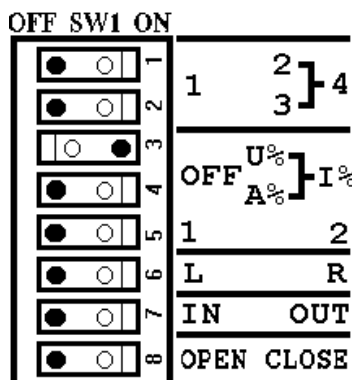

- The black dot shows which side the rocker is pushed down.

Control signal for the fans (0-10 V) is taken from the connecting PCB, where heating (on/off), sprinkling and humidifying also connects.

The "0-10 V PROG" output may serve actuator motors that is controlled by the "classic" 0-10 V signal.

There should be mounted "Resistor/Capacitor network" across the coil of all magnet valves and contactors.

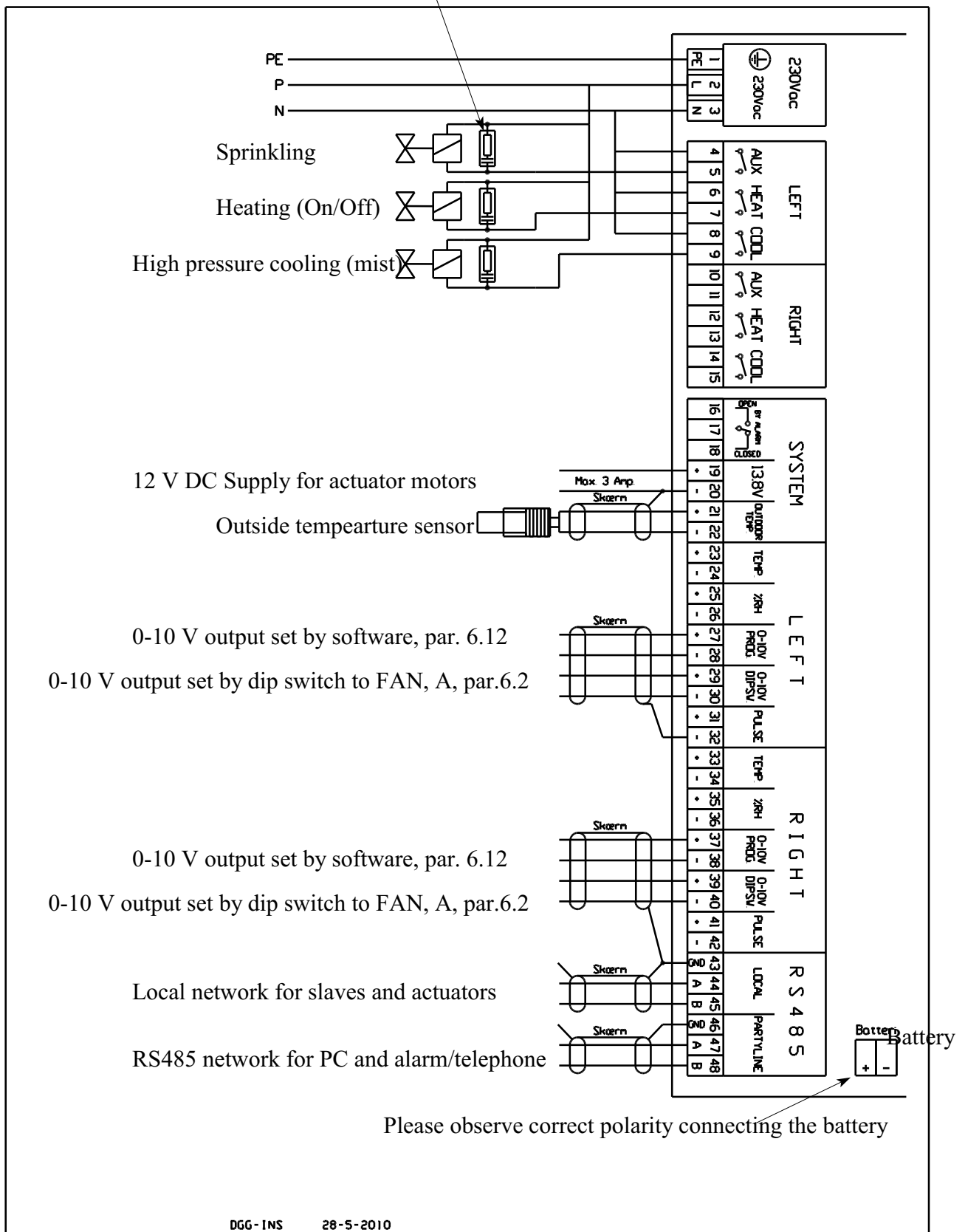

Dry and wet temperature sensor, "Psychro-Sensor"

Left Room

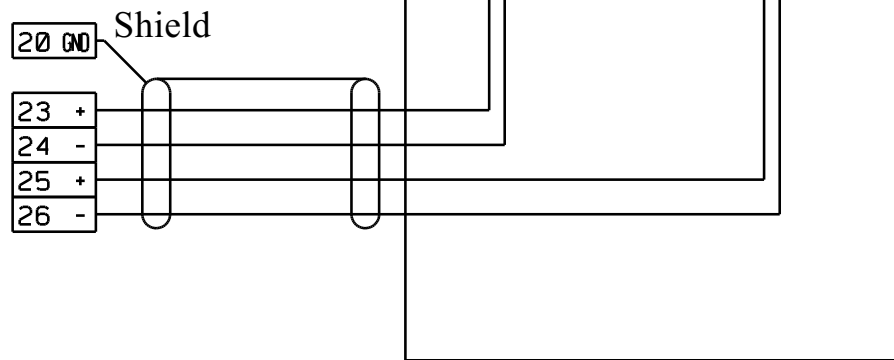

Right Room

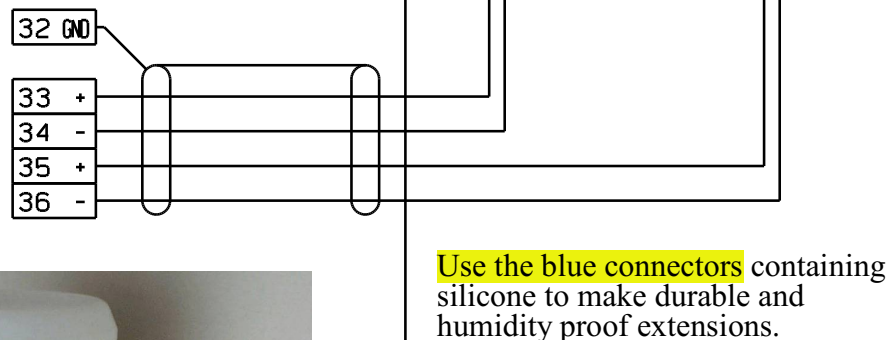

Use the blue connectors containing silicone to make durable and humidity proof extensions.

Please, observe correct polarity, when connecting the sensors !
plus = white and minus = brown.



Wiring the Actuator Motors

I_{max}

SM58c/10:	1.8A
SM58c/14:	2.3A
SM58c/30:	2.3A
SM59c/13:	1.8A
SM59c/20:	4.0A
SM59c/60:	5.0A

The power supply for the actuator motors may require a higher thickness of the cable.

How to calculate the :

$$\text{Thickness of the Cable Conductors} = \text{Length} \times I_{\text{max}} \times .035$$

Bringing the power supply closer to the motor helps keeping the need for thickness down

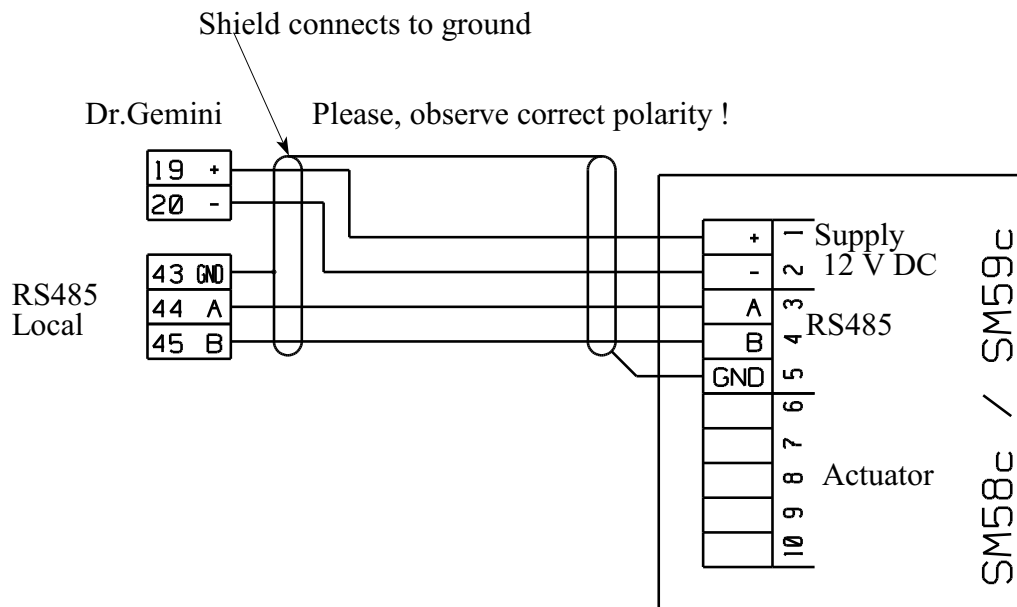

High Pressure Cooling Function

There should be mounted "Resistor/Capacitor network" across the coil of all magnet valves and contactors.

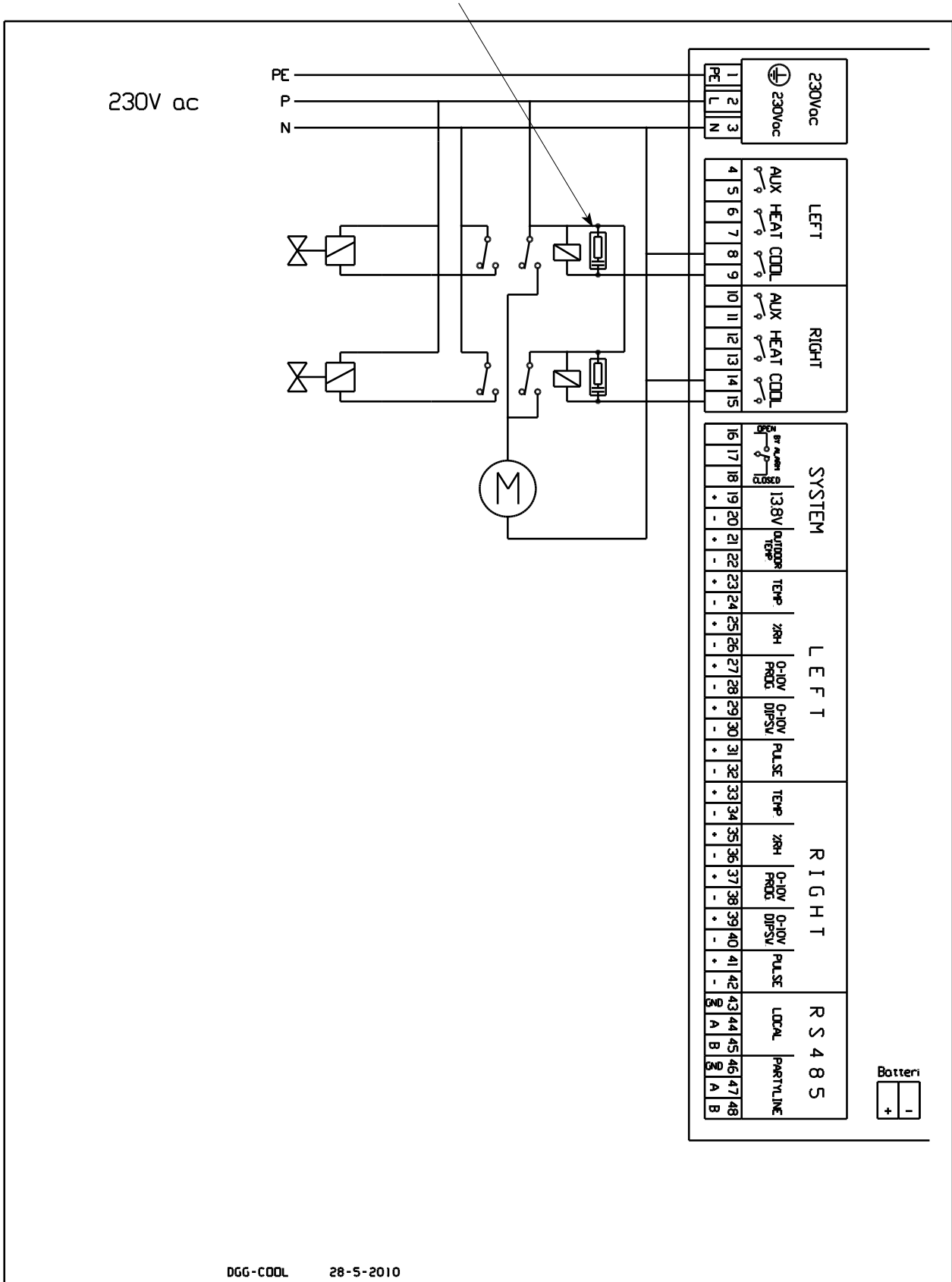

Scanning the local units

Please, refer to PAR 6.7 , 6.8 and 6.9 in the User Guide for how to scan the local units and learn more about the information on display , being received from the local units