

# Dr.Lavoisier

## OXYGEN MONITOR



# USER'S GUIDE

VERSION 1.07



## 1.1 Unlock Keyboard to Change Settings

Enter **CODE** (default "1") and press **START STOP** for 2 sec. There will sound four beeps.

To change the **CODE**, set the code you want and press **START STOP** for two secs. Write the code down to remember. If you don't have the code, you will have to make reset as described in chapter **2.4**. You may also choose to have no code at all, see **6.2**

## 1.2 Change of Settings

The arrow buttons is used to change settings.

	Rises the value
	Reduces the value

## 1.3 Setting of TIME and DATE

Push **TIME DATE** once, twice and three times to show time, date and year.

Time is used by the data logger to mark the measuring of each log entry.

## 1.4 Shut Off Siren by Alarm

- **By default** dip switch setting, no. 4 = ON (enable keyboard locking), see **6.2**

Push **START STOP** to enter "service break" - mode: The siren/red flashlight stops - green flashlight continues flashing.

During the service break you will have to provide normal oxygen level - or at least exceeding the **LOW ALARM** level. You may also change the setting of this.

The service break duration is by default 10 minutes, but may be altered, see **2.4**

When the service break has ended, normal monitoring will be reestablished.

- If you need to **completely shut off monitoring**  , you will have to unlock keyboard (**1.1**) and turn knob to **ALARM** and press **START STOP**. Display will show "OFF" and **ALARM-LED** will be turned off.

- **Using by no code mode**, dip switch setting, no. 4 = OFF (**not recommended**), see **6.2**

Turn knob to **ALARM** and press **START STOP**. Display will show "OFF" 

Press once again to activate oxygen monitoring again.

## 2.1 Present Oxygen Level Measurement

O <sub>2</sub>	Present oxygen level measurement
----------------	----------------------------------

## 2.2 Two Levels of Low O<sub>2</sub>, Warning and Alarm

<b>LOW O<sub>2</sub> WARNING</b>	O <sub>2</sub> warning level to let you take some steps to avoid further drop in O <sub>2</sub> level (default 19.0)
<b>LOW O<sub>2</sub> ALARM</b>	O <sub>2</sub> alarm level at which point you must leave the room (default 17.0)

## 2.3 High O<sub>2</sub> Warning

<b>HIGH O<sub>2</sub> WARNING</b>	O <sub>2</sub> warning level to let you know that you should calibrate the oxygen probe or investigate other reasons to a rise in O <sub>2</sub> reading
-----------------------------------	--

## 2.4 System

Various information are found in the menu "SYSTEM". Push **START STOP** to change to the next item.

<b>SYSTEM</b>	Power supply Voltage (DC) Normally 13.5 V±0.2 V by fully charged battery.
Push <b>START STOP</b> once	Station number, when used in combination with Dr.Bell Speech processor, default "1"
Push <b>START STOP</b> twice	Version number
Push <b>START STOP</b> three times	Dip switch settings (binary)
Push <b>START STOP</b> four times	Service break duration, 1-60 minutes, default 10 minutes.
Push <b>START STOP</b> five times	Reset to factory settings by pressing both arrow keys at the same time. TIME, DATE and Year must be set again.

## 3.1 Oxygen Monitoring, on/off

Point the knob towards the menu **ALARM**

Oxygen monitoring may be activated or switched off by pushing **START STOP**





Pushing **START STOP** does the same in the first four menus too !



The red "ALARM" LED	Function
lit	Monitoring active and OK
flashes	Alarm condition
off	Oxygen monitoring switched off

## 3.2 Test the Alarm

The alarm relay is in no-current-situation by alarm.

ALARM +  	tESt are shown. Red flash + siren should be activated
---	---

Push a button, or turn knob to stop testing.

## 3.3 Alarm States

Double Beep sounds every 10 seconds and the red "ALARM" LED flashes by alarm condition.



Point the knob towards the menu **ALARM**  
The code in the display indicates what the cause is.

CODE	Alarm State	LED Flash + Beeps every 10 sec.	Green Flash	Red flash + optional Siren
-1	Oxygen monitoring off 	(LED off)		
0	Monitoring active and OK	(LED on)		
1	Too Low O <sub>2</sub> Warning			
2	Too Low O <sub>2</sub> Alarm			
3	Too High O <sub>2</sub> Warning. (Presumably faulty reading)			
4	Input short-circuit			
9	Battery test warning. During 8 o'clock test, voltage dropped below 11.7 V			6 sec on 60 sec.off
10	Battery test alarm. During 8 o'clock test, voltage dropped below 11.5 V			6 sec on 60 sec.off
11	Power supply below 11.5 V			6 sec on 60 sec.off
12	Power supply below 12.5 V (Power Failure). Normally 13.6 V±0.2 V			6 sec on 60 sec.off

## 4.0 Historical Data, Data-logging

Every 10 minutes data will be stored. Alarm condition situations will be stored on a one minute basis. Data may be transferred to a personal computer. Professor Partyline© for Windows© is used to work with these data, showing graphs etc.

### 4.1 Browsing Historical Data

It is possible to browse the stored data from the O<sub>2</sub> - readings by using the arrow buttons.

- To activate log-data browsing push **TIME DATE**, and then **START STOP** .
- The “HISTORIC” - light will flash to show that you are looking at “old” data.
- To browse the data push
  - ▲ forward in time
  - ▼ back in time

Log entry time: You may push **TIME DATE** to get the time for the log entry. Push one more time to see date and one more time to return to value for the O<sub>2</sub> - readings.

To end browse session push **START STOP**, or it will return by itself if idle for one minute .

### 5.1 Oxygen Probe

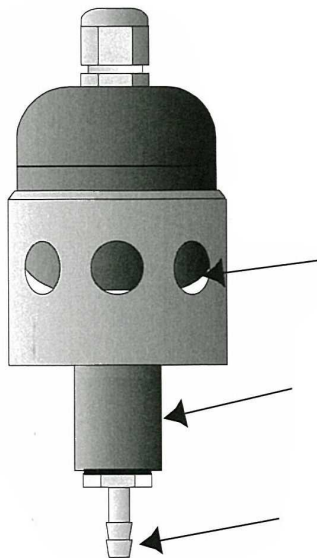

Measuring chamber

Spring loaded valve prevents calibration air affect the measuring

6 mm pipe stub for connecting a hose to supply calibration air. To be used when the air in the room cannot be trusted to have 20.9% of oxygen during calibration.

## 5.2 Oxygen Probe, Calibration

When you switch on Dr.Lavoisier, calibration should be performed. Also, after 1-2 days of stabilization, calibration should be repeated. Once a week, check the reading, when the probe are exposed to normal air with 20.9% oxygen. If necessary supply air through a hose connected to the pipe stub.

Calibration of the oxygen should be done if readings by fresh air differs more than 1.0% from 20.9%.

<b>CALIBRATION</b>	Place the sensor in fresh air. Push both arrow buttons at the same time. There will sound four beeps. The figure in the display should show a value between 0.500 and 3.000. Otherwise it must be repaired.
Push <b>START STOP</b>	Shows the value of O <sub>2</sub> level in fresh air = 20.9 %. Do not change more than 1% to compensate for barometric pressure ! Unless used to other special task. This value is used to calibrate.

The measuring performed by Dr.Lavoisier are not compensated for the influence of **barometric pressure**. Readings are in direct relation to the barometric pressure. When calibrating you might take this into account.

Barometer reading, hPa	O <sub>2</sub> reading
970 (very,very low)	20.0
1013 (normal)	20.9
1056 (very, very high)	21.6

The critical oxygen level is said to be around 13.0 %. LOW O<sub>2</sub> ALARM is default set to 17.0%. Variations in barometric pressure will affect the O<sub>2</sub> reading by less than 1%.

## 5.3 Oxygen Probe, Repair

Membranes, O-rings, electrolyte and "pot scourer" are provided for repair of the oxygen probe.

### Repair:

1. Unscrew the cap, discard the electrolyte and the membrane from the inside, and clean all parts. The cathode may be cleaned with the "pot scourer" provided..
2. Place a new membrane + O-ring and fill the cap with electrolyte.
3. Put the top and the cap together and engage the thread by half a turn. Locate the flat part of the thread and tilt the probe 15° with the flat part as the uppermost. Turn to screw the cap and the top part together. Excess electrolyte will escape at the flat part.
4. Check that the membrane is flat and correctly positioned. Shake the probe to check that the probe is completely filled (no splashing when shaken !)

Please find picture on the next page

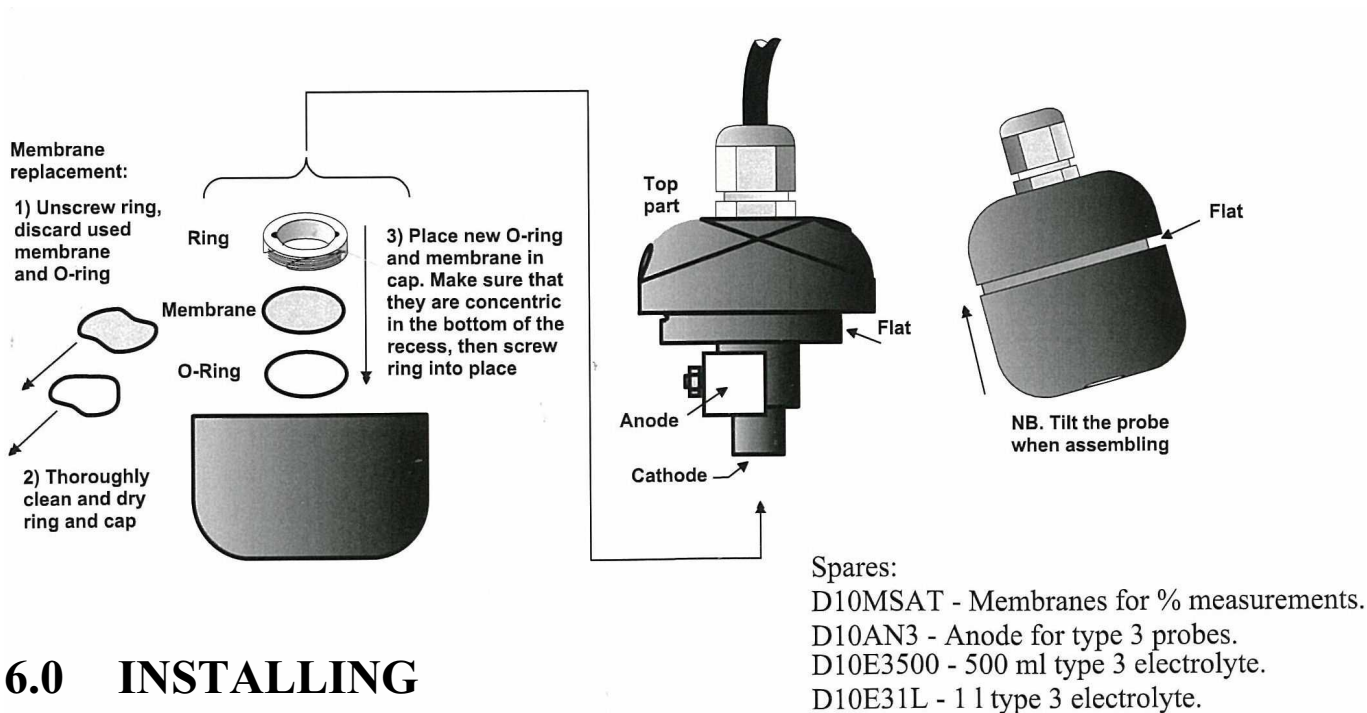

## 6.0 INSTALLING

### 6.1 Cable Connections

Cables for oxygen probe, communication RS485 and alarm signals (siren and flash) must be shielded if longer than 3 meters, and they should be separated from power cords (10 centimeters). Shield should be connected to terminal 11, 22, 25.

Important : wires to oxygen probe, battery, siren and flash lamps must be connected properly according to the color-codes (plus and minus)

### 6.2 Dip Switch Settings

Default settings are switch # 4, 6 and 7 in ON position.

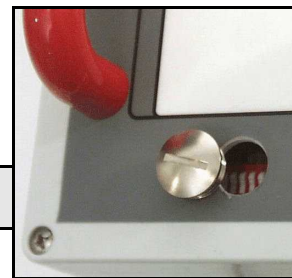

No.	OFF (=OPEN)	ON
1	Default	-
2	Default	-
3	Default	-
4	Disable keyboard locking  (no CODE mode, <b>not recommended</b> )	Enable keyboard locking. <span style="float: right;">Default</span>
5	Beebing by alarm situation enabled. Default	Beebing by alarm situation disabled.
6	Battery test disabled	Battery test enabled. <span style="float: right;">Default</span>
7	Telephone call enabled	Telephone call disabled. <span style="float: right;">Default</span>
8	Default	By power on: Memory reset. Default settings established.

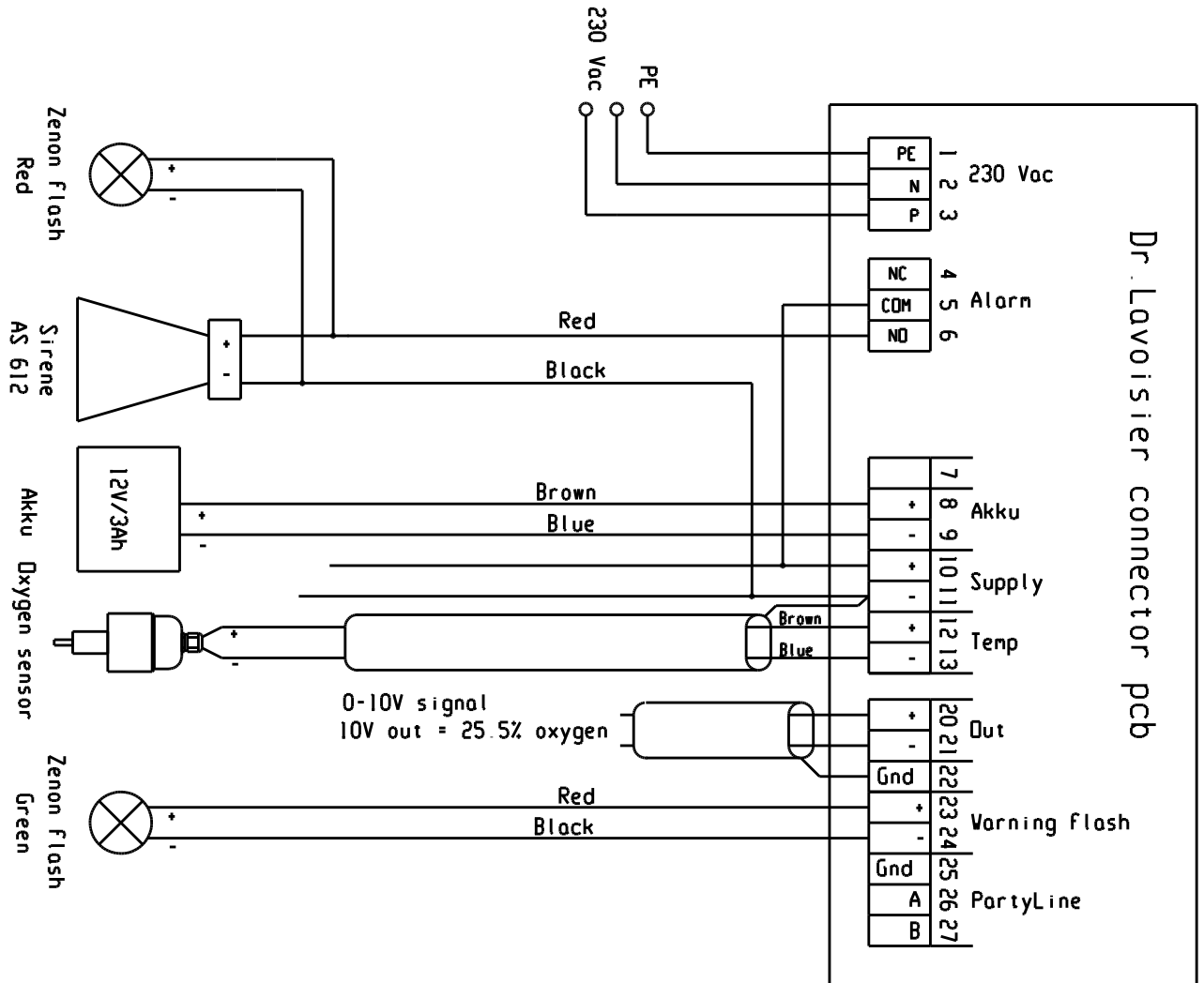

**Dr. Lavoisier**  
**Oxygen supervisor**  
**Installation**

DL2-INS 9/6-2004